

TB8100 base station

Connecting to a TB8100 via Ethernet



Contents

- 1 **Overview** 3
- 2 **Applicability** 3
- 3 **Functional Description** 4
- 4 **Connection** 6
 - 4.1 Site and Network Connections 6
 - 4.2 Base Station Connections 8
 - 4.3 Service Kit Connections 12
 - 4.4 Calibration Kit Connection 13
- 5 **Network Configuration** 14
 - 5.1 Configuring the Base Station Network Identity 14
 - 5.2 Defining Routes for a Networked PC 15
- 6 **Testing** 16
- 7 **Syslog Messages** 17
 - 7.1 Syslog Operation 17
 - 7.2 Message Format 18
 - 7.3 Heartbeat Messages 19

Associated Documentation

TB8100 Installation and Operation Manual (MBA-00005-xx).
TB8100 Specifications Manual (MBA-00001-xx).
TB8100 Service Kit User's Manual (MBA-00010-xx) and online Help.
TB8100 Calibration Kit User's Manual (MBA-00011-xx) and online Help.
TB8100 Alarm Center User's Manual (MB8100-80-00-806) and online Help.
TN-742-AN: Remotely Monitoring and Configuring the TB8100.
TN-947-AN: TB8100 Base Station Computer Controlled Interface (CCI) Protocol

1 Overview

This Application Note provides information on the TaitNet Ethernet system interface board. The TaitNet Ethernet board is fitted to the reciter and provides the TB8100 base station with an Ethernet interface, allowing it to be integrated into IP networks. The TaitNet Ethernet board also has an enhanced TaitNet interface.

Some of the advantages of the Ethernet functionality are:

- Monitoring and diagnostics can be performed from any location where there is an IP connection to the site.
- Alarms can be reported to a syslog server.
- The Ethernet connection can be used to download firmware, to read and program configurations, and also for CCI mode.

This Application Note is intended for use by system integrators.

2 Applicability

Ethernet connectivity is only available on reciters which are fitted with a TaitNet Ethernet system interface board. These reciters can be identified by the following product codes:

- TBA4xxx-0K0x
- TBA5xxx-0K0x (receive-only).

3 Functional Description

Introduction

The TaitNet Ethernet system interface board enables the TB8100 to be integrated into IP networks, for example those used for microwave links between sites (refer to [Figure 1 on page 7](#)). The TB8100 Service Kit has also been modified to support Ethernet connection, allowing all its features such as configuration, firmware downloading, monitoring and diagnostics to be performed from any location where there is an IP connection to the site.

The TB8100 TaitNet Ethernet system interface board is designed for use with all TB8100 base station systems, including paging, TaitNet trunking, and TaitNet QS² Simulcast. It supports Computer Controlled Interface (CCI) commands, but does not support VoIP. It also supports auto speed detection of either 10 or 100 base T.

The TaitNet Ethernet system interface board requires reciter firmware version 3.00 and later. PSTN Alarm Center dial-up and email services are disabled when a TaitNet Ethernet system interface board is fitted (refer to [“Syslog Messages” on page 17](#)), but are still supported on other system interface boards.

Alarm Processing

Alarm processing has been enhanced from the solution previously available, which involved the use of a PSTN, asynchronous port switch, and Alarm Center. TB8100 base stations using an Ethernet connection cannot connect to an Alarm Center. Instead, the TaitNet Ethernet system interface board sends industry standard “syslog” TCP-IP messages to a syslog collector. The syslog collector then displays the alarm notifications and, depending on the actual collector used, can add further customised actions. Refer to [“Syslog Messages” on page 17](#) for further details on the syslog collector.

A typical process for TB8100 fault management via Ethernet would be as follows:

1. A base station detects a fault and sends a syslog message to a syslog collector.
2. Depending on the particular syslog collector being used, the collector then:
 - Translates the message into an email notification for sending, based on various priority rules.
 - Generates audible warnings, etc., or translates the message into an SNMP trap for another SNMP-based notification service to use.
3. Once the fault has been notified, the TB8100 Service Kit may be used to access the base station and diagnose the fault.

Ethernet and System I/O

The TaitNet Ethernet system interface board has an RJ45 Ethernet connector and an enhanced 15-way D-range connector. Some pins on the D-range connector can be configured to provide different signals. [“Base Station Connections” on page 8](#) has more information on these switch-selectable signals and the pin allocations of the D-range.



Note The pin allocations for the 15-way D-range connector on the TaitNet Ethernet system interface board are different from those of other TaitNet boards (refer to [“Base Station Connections” on page 8](#)).

Monitoring Heartbeats

Using the Service Kit you can configure the TB8100 to send a regular heartbeat message. The interval between heartbeats can be set from one minute to 12 hours. This enhances network fault monitoring because, if the syslog collector fails to receive a periodic message from a base station, it can raise the appropriate alarm.

The heartbeat output is disabled when CCI mode is active, because it is expected that the remote device connecting to the base station will poll the base stations to validate the communications link. There is also no heartbeat if the Service Kit is connected.

Refer to [“Syslog Messages” on page 17](#) and the Service Kit documentation for more information.



Note Only one type of connection to a TB8100 is possible at any one time (either the Service Kit, or syslog, or CCI).

Power Saving

Power Saving is still possible with the TaitNet Ethernet system interface board. However, the total power consumption will be slightly greater (for example, approximately 1 W more than the isolated system interface board).



Note The state of the digital inputs and outputs will be undefined during Sleep and Deep Sleep if the Rx Cycling time is set to 200ms or longer.

4 Connection

4.1 Site and Network Connections

Site Connections [Figure 1](#) shows typical connections for a site linked by microwave.

Network Connections [Figure 2](#) shows an example of interconnections between TB8100 base stations, a network, a syslog collector, and the Service Kit.

It is also possible for customer-specific software applications to receive the syslog message directly and integrate the handling of the message into existing processes.

Ethernet Connections The pin allocations of the Ethernet connector are configured for a straight-through network cable (refer to [“Ethernet” on page 11](#)). If you want to connect directly to a computer's Ethernet port, you will need to use a cross-over cable.



Note The TB8100 does not support multiple, simultaneous Ethernet connections. The Ethernet interface is only able to carry out one Ethernet function at a time: either Service Kit connection, CCI command protocol, or Syslog messaging. While one of these functions is in progress, all other Ethernet functions are blocked until the current Ethernet connection is terminated.

Figure 1 Typical site connections

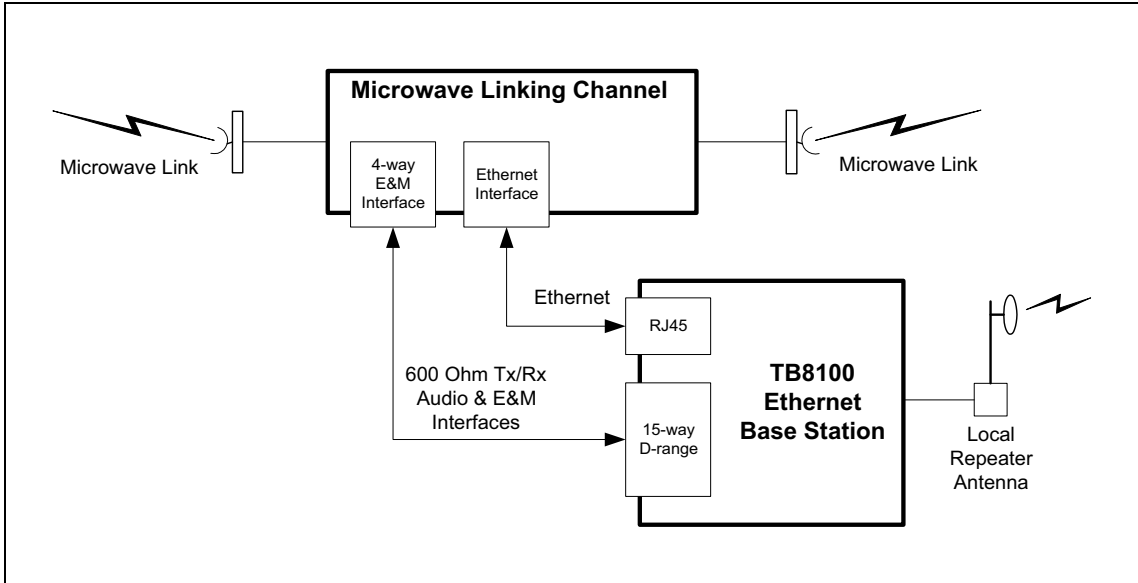
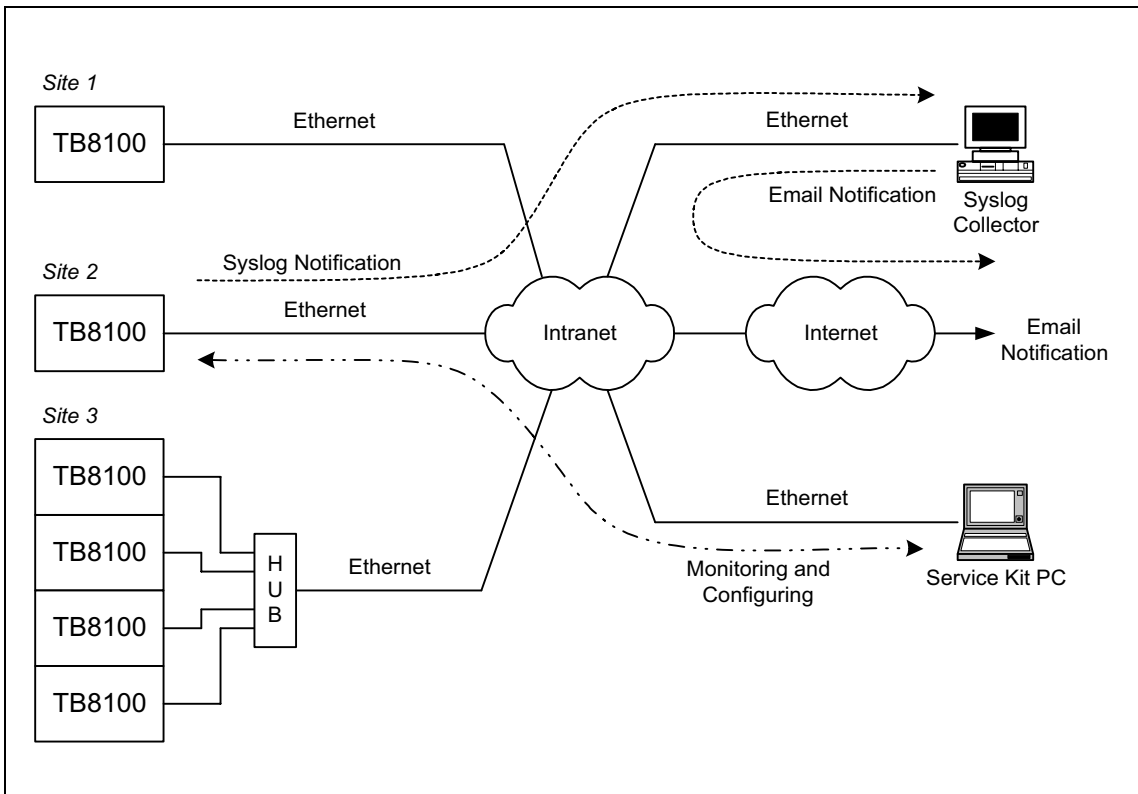

Figure 2 Example network connections



4.2 Base Station Connections

The system connectors mounted on the TaitNet Ethernet system interface board are accessible at the rear of the reciter. These connectors are:

- a 15-way D-range for system inputs and outputs (system interface)
- an RJ45 for Ethernet
- a 2-way connector for auxiliary DC input from a PMU.

These connectors are described in more detail below.

System Interface

Some pins on the 15-way D-range connector can be configured to provide different signals. These pins are as follows:

- pins 3, 4, 5 and 6 can be configured for Rx gate, Tx key and unbalanced audio, **or** E&M signalling
- pin 11 can be configured for RSSI **or** Tx relay.

You can select which signal is connected to each pin by setting switches S1 and S2 on the system interface board.



Important You must set both switches correctly for each D-range pin. Setting the switches incorrectly may result in both signals being connected to the pin at the same time, or no signal at all being connected.

The pin allocations and switch settings for the factory default and optional signals are listed in [Table 1 on page 9](#). [Figure 3 on page 10](#) shows the location of switches S1 and S2 on the board, and also provides a pictorial guide to their settings.



Note The pin allocations for the 15-way D-range connector on the TaitNet Ethernet system interface board are different from those on other TaitNet boards. These differences are described in [Table 2 on page 10](#).

Table 1 Pin allocations for the TaitNet Ethernet D-range connector

Pin	Signal Name	Switch S1 & S2 Settings		Signal Type	Notes
		On	Off		
1	Rx line out +			audio output	transformer isolated line
2	Rx line out –				
3	Rx audio out ^a or opto +/-	S1:5 S1:6	S1:6 S1:5	audio output isolated keying input	input voltage range ±10VDC to ±60VDC
4	Rx gate ^a or relay +/-	S1:3 S1:4	S1:4 S1:3	output isolated gate output	open collector
5	Tx key ^a or relay -/+	S1:7 S1:8	S1:8 S1:7	input isolated gate output	
6	Tx audio in ^a or opto -/+	S1:1 S1:2	S1:2 S1:1	audio input isolated keying input	input voltage range ±10VDC to ±60VDC
7	Tx line in +			audio input	transformer isolated line
8	Tx line in –				
9	+AUX_V			power output	from auxiliary DC input
10	digital in/out 1 ^{bc}			input	5V TTL logic, active low
11	RSSI ^a or Tx relay	S2:8 S2:7	S2:7 S2:8	DC signal output	open collector
12	digital in/out 2 ^b			input	5V TTL logic, active low
13	digital in/out 3 ^b				
14	digital in/out 4 ^b				
15	ground			ground	

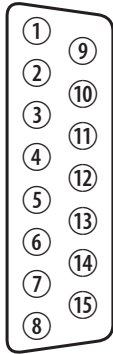

external view

- a. Factory default settings.
- b. Digital inputs 1, 2, 3, and 4 may also be configured as outputs using a Task Manager statement. For more details refer to “Digital Interface” in the “Connection” chapter of the Installation and Operation Manual, and to the Service Kit documentation.
- c. If a base station with a 12V PA is configured for Deep Sleep, digital out 1 is dedicated to Power Saving control and cannot be used for any other Task Manager function.

Table 2 Differences between the TaitNet Ethernet D-range connector and other TaitNet connectors

Pin	TaitNet Ethernet Signal Name	TaitNet and TaitNet RS-232 Signal Name
10	digital in/out 1	digital out 3
11	RSSI	no connection
12	digital in/out 2	digital out 1
13	digital in/out 3	digital out 2
14	digital in/out 4	digital in 1

Figure 3 Setting switches S1 and S2

Factory default settings

Rx gate, Tx Key, unbalanced audio

S1

ON							
↑	↓	↑	↓	↑	↓	↑	↓
1	2	3	4	5	6	7	8

S2

ON							
↑	↑	↑	↑	↑	↑	↓	↑
1	2	3	4	5	6	7	8

switches 1 to 6 not used

Optional settings

E&M signalling

S1

ON							
↓	↑	↓	↑	↓	↑	↓	↑
1	2	3	4	5	6	7	8

S2

ON							
↑	↑	↑	↑	↑	↑	↑	↓
1	2	3	4	5	6	7	8

switches 1 to 6 not used

Ethernet

The pin allocations for the RJ45 Ethernet connector are given in the following table.

Pin	Signal	Description
1	Tx +	transmit data +
2	Tx –	transmit data –
3	Rx +	Ethernet receive data +
4		terminated
5		terminated
6	Rx –	Ethernet receive data –
7		terminated
8		terminated

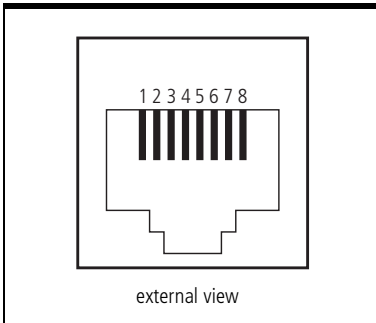

The diagram shows an external view of an RJ45 Ethernet connector. It is a rectangular connector with a notch at the bottom. Eight pins are visible, numbered 1 through 8 from left to right. The pins are arranged in a standard T568B wiring scheme.

Auxiliary DC Input

The system interface board also has a 2-way auxiliary DC input connector. DC from the auxiliary DC output on the PMU can be supplied to the +AUX_V pin on the system interface connector via this input. Refer to the Installation and Operation Manual for more information on this connection.

4.3 Service Kit Connections

There are various ways of connecting the Service Kit to a TB8100 base station that is fitted with a TaitNet Ethernet system interface board. These are described briefly below. Refer also to the Service Kit documentation.



Note The TB8100 does not support multiple, simultaneous Ethernet connections. The Ethernet interface is only able to carry out one Ethernet function at a time: either Service Kit connection, CCI command protocol, or Syslog messaging. While one of these functions is in progress, all other Ethernet functions are blocked until the current Ethernet connection is terminated.



Note Only one Service Kit can connect to the base station at one time.

Direct Connection to the Control Panel

You can use an ordinary RS-232 modem cable to connect the serial port on the Service Kit PC to the serial port on the base station's control panel. This connection is available only when the base station first powers up.

1. Connect a serial cable from the Service Kit PC to the control panel.
2. Run the Service Kit and click **Connect**. In the Connecting dialog box, select a direct connection, and click **Connect**.
3. Power up the base station.



Note When the base station is configured with a zero IP address (i.e. the IP address field in the Service Kit is blank), direct connection at the control panel is always available. There is no need to restart the base station.



Note When a reciter fitted with a TaitNet Ethernet system interface board is first powered up, the Service Kit (or Calibration Kit) can connect via the reciter's front panel serial port (16-way IDC connector). If the reciter detects no activity on this port, it will switch to communicating via the system interface board. All connection via the front panel serial port will then be disabled until the next power cycle.

Direct Connection by Ethernet Crossover Cable

You can connect the Service Kit PC directly to the RJ45 Ethernet connector on the base station using an Ethernet crossover cable.

1. Connect an Ethernet crossover cable from the Service Kit PC to the RJ45 connector at the rear of the reciter.
2. Configure the Service Kit PC with a fixed IP address that is on the same subnet as the base station's IP address. The PC will not be able to obtain an IP address automatically. On some versions of Windows, you will need to restart the PC.



Note If the base station has the default IP address (192.168.1.2), configure the Service Kit PC as follows:

IP address: 192.168.1.3
subnet mask: 255.255.255.0
default gateway: none.

3. Run the Service Kit and click **Connect**. In the Connecting dialog box, select the appropriate network connection for the base station, and click **Connect**.

Local Connection by Ethernet at a Radio Site

Before connecting a Service Kit PC to the Ethernet at a site, you must configure the PC with an appropriate fixed IP address.

1. Configure the Service Kit PC with a fixed IP address that is on the same subnet as the base station at the site.
2. At the site, use a normal (non-crossover) Ethernet cable to connect the PC to a spare port on the switch or hub.
3. Run the Service Kit and click **Connect**. In the Connecting dialog box, select the appropriate network connection for the base station, and click **Connect**.

Remote Connection over the Network

If both the Service Kit PC and the base station have network access, you can make a remote Service Kit connection.

1. Ensure that the Service Kit PC has network access, either via an office network, or via modem to an ISP.
2. Run the Service Kit and click **Connect**. In the Connecting dialog box, select the appropriate network connection for the base station, and click **Connect**.

Lost or Forgotten IP Address

If you misplace the IP address of the base station, connect to the reciter in the normal way using RS-232, as described in “[Direct Connection to the Control Panel](#)” on page 12. You can then read or configure the IP address without using the network interface.

4.4 Calibration Kit Connection

The Calibration Kit still connects via RS-232. You must connect the Calibration Kit to the reciter’s front panel serial port (via the control panel or a Calibration Test Unit) as described in the Calibration Kit documentation.



Note When a reciter fitted with a TaitNet Ethernet system interface board is first powered up, the Calibration Kit (or Service Kit) can connect via the reciter’s front panel serial port (16-way IDC connector). If the reciter detects no activity on this port, it will switch to communicating via the system interface board. All connection via the front panel serial port will then be disabled until the next power cycle.

5 Network Configuration

5.1 Configuring the Base Station Network Identity

IP Address This is the unique number that identifies this particular base station. The address is allocated by the network administrator, and is only valid within that network.

Typically, you will need to add a route to any PC that wishes to connect to the base station from outside the network (refer to [“Defining Routes for a Networked PC”](#) on page 15).

On the TB8100, the IP address 0.0.0.0 (i.e. the IP address field in the Service Kit is blank) means that the Ethernet interface is not enabled, and the base station will not appear on the network at all. When configured with this address, direct Service Kit connection remains permanently available at the control panel.

Subnet Mask The subnet mask is a bit mask used to tell how many bits in the IP address identify the particular subnetwork, and how many bits (the rest) represent an individual host within that subnet. For instance, a subnet mask of 255.255.255.0 means that the first 24 bits (3 8-bit bytes) of the IP address identify the subnet, and the remaining 8 bits identify a particular host (e.g. a base station or Syslog server) within that subnet. The subnet mask will be determined by the network administrator.

Default Gateway The default gateway address is used by the base station when an IP packet's destination address is outside the local subnet. The default gateway is usually an interface belonging to a router that is connected to the outside world. The default gateway address will be determined by the network administrator, and may be left blank.

5.2 Defining Routes for a Networked PC

You may need to define routes so that the Service Kit PC uses the correct IP routing path to the base station subnet. Without a correct entry in the network routing table, the Service Kit will be unable to remotely connect to the base station. You can provide this using the “route” command. The operating system Help gives assistance on the use of this command.

To define a route, proceed as follows:

1. Select Start > Run.
2. Enter “cmd”.
3. At the command line prompt, enter “route print”.
4. If the displayed list of persistent routes at the bottom of the output does not provide a route to the base station subnet, add one or more persistent routes in the format:

```
route -p add destination mask subnetmask gateway
```

For example:

```
route -p add 172.16.16.0 mask 255.255.240.0 172.25.206.252
```

This example tells the PC that all packets destined for the 172.16.16.0 subnet will need to go via the gateway router found at 172.25.206.252.

6 Testing

You can use “ping” to check the connection to a base station. To use ping under Windows, proceed as follows:

1. Select Start > Run.
2. Enter “cmd”.
3. At the command line prompt, enter “ping *IP address*”.

For example:

```
ping 172.16.16.0
```

Typical responses are as follows:

```
Request timed out
```

Either the connection is faulty, or an intervening gateway is blocking access to the ping service. Consult your network administrator.

```
Reply from 172.16.16.0: bytes=32 time<10ms TTL=64
```

The connection is OK.

7 Syslog Messages

When TB8100 base stations have Ethernet connections instead of RS-232, they are not able to communicate with a Tait Alarm Center. Instead, they can send any alarms as syslog messages to a syslog collector. Other elements in the network such as routers and switches can also be configured to send syslog messages to the syslog collector.

Computers running Unix or Linux have a syslog collector as part of their operating system. Windows-based PCs need a suitable third party syslog collector. Tait has tested the TB8100 with the Kiwi Syslog Daemon (see www.kiwisyslog.com). The Kiwi Syslog Daemon is able to handle the syslog messages of Cisco routers as well. The freeware version can be used to explore its capabilities, but the registered version offers useful additional functions, such as the ability to display different screens for different base stations.

To use syslog messages in your system, proceed as follows:

- Use the Service Kit to enable and configure the sending of alarm messages to the Syslog collector (Configure > Communications > Syslog).
- Configure the syslog collector to listen for TCP syslog messages.



Note TB8100 syslog messages are sent as TCP packets and, by default, the Kiwi Syslog Daemon does not listen to them. In the Kiwi Syslog Daemon, select File > Properties > Inputs > TCP > Listen for TCP Syslog Messages, TCP Port 1468.

- **Optional:** Set things up to monitor base station failure. First, use the Service Kit to enable the sending of a heartbeat and to configure its interval. Then set up a script in your syslog collector that takes action if the heartbeat is not received (emails the technician, pages the technician, or sends a syslog message).
- **Optional:** Set up your syslog collector to email the duty technician when significant error messages are received from a TB8100 or a router.

7.1 Syslog Operation

The TB8100 optionally sends syslog messages in Standby and in Run modes.

Because the Ethernet interface communicates internally via RS-232, the TB8100 cannot send syslog messages when it is in CCI mode or when a Service Kit is connected. The fault log is able to store up to 50 messages until they can be sent.

TB8100 syslog messages are not fully reliable, even though they use TCP. They can be lost if Internet traffic is particularly heavy. This is due to limitations of the base station's Ethernet device. Syslog messages are also lost if the fault log becomes full, for example during a long Service Kit session.

Task Manager actions can disable the sending of syslog messages. The fault log continues to store any messages that are generated, and they are sent when Task Manager re-enables the syslog service.

If Task Manager clears the alarm log, any syslog alarm messages that have not already been sent are lost.

7.2 Message Format

TB8100 syslog messages have the following format:

IP address module: timestamp, alarm code - text

For example:

172.25.206.17 SYSTEM: 94608624.312, 007 – Unbalanced Line Input Low

They appear in the Kiwi Syslog Daemon like this:

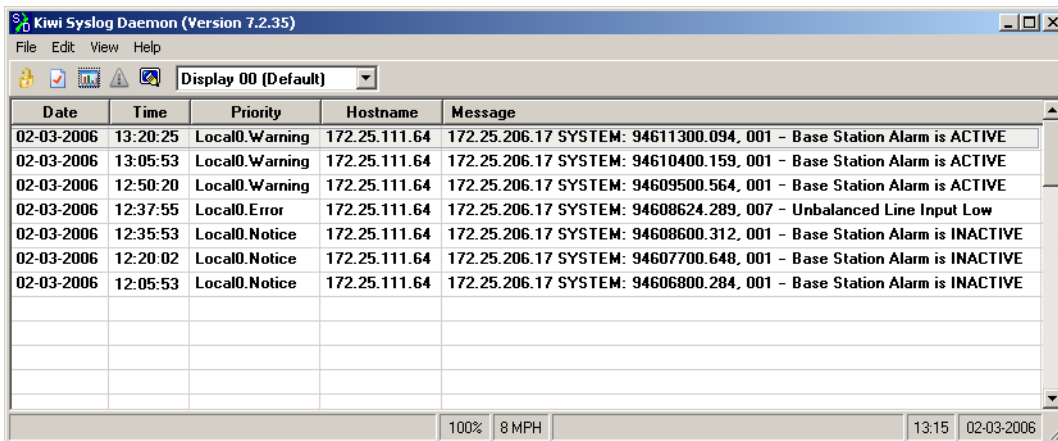

Date	Time	Priority	Hostname	Message
02-03-2006	13:20:25	Local0.Warning	172.25.111.64	172.25.206.17 SYSTEM: 94611300.094, 001 – Base Station Alarm is ACTIVE
02-03-2006	13:05:53	Local0.Warning	172.25.111.64	172.25.206.17 SYSTEM: 94610400.159, 001 – Base Station Alarm is ACTIVE
02-03-2006	12:50:20	Local0.Warning	172.25.111.64	172.25.206.17 SYSTEM: 94609500.564, 001 – Base Station Alarm is ACTIVE
02-03-2006	12:37:55	Local0.Error	172.25.111.64	172.25.206.17 SYSTEM: 94608624.289, 007 – Unbalanced Line Input Low
02-03-2006	12:35:53	Local0.Notice	172.25.111.64	172.25.206.17 SYSTEM: 94608600.312, 001 – Base Station Alarm is INACTIVE
02-03-2006	12:20:02	Local0.Notice	172.25.111.64	172.25.206.17 SYSTEM: 94607700.648, 001 – Base Station Alarm is INACTIVE
02-03-2006	12:05:53	Local0.Notice	172.25.111.64	172.25.206.17 SYSTEM: 94606800.284, 001 – Base Station Alarm is INACTIVE

Date and Time Syslog collectors display the date and time that the message was received.

Priority The priority consists of a facility code and a severity level. The default facility code used by TB8100s is Local0. The severity for alarms is Error.



Note Heartbeat messages have a severity of Notice if an alarm is inactive, and a severity of Warning if an alarm is active.

Hostname The host name or IP address that appears in the “sender” field of the TCP packet containing the syslog message. If the network uses NAT, this will be different from the IP address of the base station.

Message

The message part of a TB8100 syslog message has the following parts:

IP Address	The IP address of the TB8100 that originated the syslog message.										
Module Code	The module code indicates which base station module generated the message: <table><thead><tr><th>Module Code</th><th>Module</th></tr></thead><tbody><tr><td>SYSTEM</td><td>TB8100 base station</td></tr><tr><td>REC</td><td>reciter</td></tr><tr><td>PA</td><td>power amplifier</td></tr><tr><td>PMU</td><td>power management unit</td></tr></tbody></table>	Module Code	Module	SYSTEM	TB8100 base station	REC	reciter	PA	power amplifier	PMU	power management unit
Module Code	Module										
SYSTEM	TB8100 base station										
REC	reciter										
PA	power amplifier										
PMU	power management unit										
Timestamp	The timestamp gives the value of the base station timer since its last start-up. It consists of a number of seconds and milliseconds.										
Alarm Code	The alarm code is the last three characters of the CCI data tag for the alarm (for a list of CCI data tags, see TN-947-AN).										
Text	The text is an English description of the reason for the message.										

7.3 Heartbeat Messages

The TB8100 can send a regular heartbeat message. You can enable this function and select an interval between heartbeats using the Service Kit. If there is an alarm, the heartbeat is given a severity of Warning (4), and its MSG is as follows:

```
SYSTEM:Timestamp, 001 - Base Station Alarm is ACTIVE
```

If there is no alarm, the heartbeat is given a severity of Notice (5), and its MSG is as follows:

```
SYSTEM:Timestamp, 001 - Base Station Alarm is INACTIVE
```

To set up a syslog collector to respond to base station failure, proceed as follows:

1. For each base station, set up a filter for any message from the base station's IP address.
2. Set up an action for that filter: if the syslog collector receives a message, it starts a timer.
3. Set up a duration for the timer. This needs to be long enough to cope with the unavailability of syslog messages when the base station is connected to a Service Kit, or when it is in CCI mode.

4. Set up an action if the timer expires (for example, send an email to the duty technician).

(If you are using the Kiwi Syslog Daemon, these capabilities are only available in the licensed version.)



Note There is no heartbeat when CCI mode is active or if the Service Kit is connected.

Publication Information

Issuing Authority This TN was issued by: Kurt Ebrecht
Technical Publications Manager

Distribution Level Associate, Associate System Integrator, Accredited Service Centre,
Accredited Service Centre System Integrator, or Tait Only.

Publication History

Publication Date	Author
28 April 2006	D Reynolds

Amendment Record

Publication Date	Page	Amendment
28 April 2006		First release

Tait Contact Information

**Corporate Head Office
New Zealand** Tait Electronics Limited
P.O. Box 1645
Christchurch
New Zealand

For the address and telephone number of regional offices, refer to the
TaitWorld website:

Website: <http://www.taitworld.com>

Technical Support For assistance with specific technical issues, contact Technical Support:
E-mail: support@taitworld.com
Website: <http://support.taitworld.com>

TELCOM

www.telcomsa.es

Tel. (+34) 91 103 30 00